

Research and Investigation of High Frequency Profile of Step and Touch Voltages Due to Fragmentation of the Grounding Grid

DOI: <http://dx.doi.org/10.17981/ingecuc.20.1.2024.05>

Artículo de Investigación Científica. Fecha de Recepción: 06/05/2023 , Fecha de Aceptación: 12/07/2023

Asaad Shemshadi  <https://orcid.org/0000-0002-7271-9933>

Department of Electrical Engineering, Arak University of Technology, Arak, Iran,
shemshadi@arakut.ac.ir

Pourya khorampour  <https://orcid.org/0000-0002-8718-6519>

Department of Electrical Engineering, Arak University of Technology, Arak, Iran,
poriyakhp@gmail.com

To cite this paper

As. Shemshadi & P. khorampour “Research and Investigation of High Frequency Profile of Step and Touch Voltages Due to Fragmentation of the Grounding Grid” DOI: <http://dx.doi.org/10.17981/ingecuc.20.1.2024.05>

Abstract

The increasing demand and the benefits of electricity energy have led to the creation of huge power plants, so high voltage substations are necessary for electrical energy. Installing different small power plants to prevent consumption in different parts of a country requires reservation units and high costs for repairs, maintenance and fueling. The necessity of these substations can be searched in the lack of uniformity of different costs, the costs of generating electrical energy, the lack of consumption centers near power plants, and generally the existence of a national grid and the possibility of timely disconnection of the faulty parts of the power grid. The priority in the rehabilitating of a strong substation is to meet the system's operation needs. In all electrical installations, especially in industrial complexes, land connectivity is one of the most important and fundamental measures to protect individuals and equipment and improve the performance of the system. The purpose of ground equipment system is to potentialize the metal body of all electrical equipment with the ground to prevent electrocution and protect personnel. This type of connection is not normally a current carrier, but if one of the phases of the device is connected to the fuselage, the fault current enters the ground through this connection and closes its path through the trans neutral or the generator connected to the ground. Earth networks due to different structures of the earth in different regions may cause problems over time, one of them is the fragmentation of the earth's network due to rot of conductors or due to overvoltage. In this research at different and high frequencies, we use 3 frequencies of 50, 100 kilos and 1 MHz, to check the ground network factors and the security of equipment and people in high voltage substations, we use CDEGS software which is a specialized program for designing and investigating the earth network.

Objetivo: Research and investigation of high frequency, profile of step and touch voltajes of grounding grid.

Metodología: Design and modeling with Comsol software.

Resultados: As the frequency increases, both the step voltage and the touch voltage at the corner points increase more.

Conclusiones: By comparing the voltage profiles based on the simulation results, it was found that by increasing the frequency of the contact voltage in each profile and mesh, it is noticeably increased. The point to consider after reviewing the simulation results is that by increasing the frequency of both step voltage and touch voltage in the corner points, they are more increased than other parts.

Key Words

Earthing System, Lightning, High Frequency, Earth Grid, Over Voltage, Step voltage, Touch Voltage.

I. INTRODUCTION

Earthing or grounding involves an artificial electrical connection to the ground with very little resistance to flow. In fact, the word "earth" in electrical works refers to a ground with zero potential. When a point of the grid becomes earth, it's single-ground, and when it's grounded in different places, it's called multi-earth [1]. Grounding or earthing an electrical system is the process of connecting all metal parts or metal bodies of electrical devices (other than the main conductors of the electrical circuit) to the ground, and the purpose of which is to transfer any electrical energy leakage in the metal body of the devices to the ground in order to protect the lives of employees with equipment [2]. Ground wire protection

is a form of protection in which the conductor parts of the device, which are not electrically correlated with the feeding network, are connected to the ground by the wire. Un long as no connection occurs in the body of the device, the protected parts of the device will also have the potential with the ground [3].

Earthing system follows two objectives [4]: 1- Preserving the lives of people associated with electrical devices: Creating a path from the body of electrical equipment to the ground as a body that has gained low resistance causes the current to pass through the path with less resistance in case of electrical connection of part of the circuit to the body, instead of passing through the body of the persons, so that the lives of the people are immune from the current. 2- Maintaining the health of the system regardless of safety issues: electrical appliances are generally composed of two parts, conductive and insulating, in normal operation of the circuit, all current must pass through the conductors and the insulation materials do not flow. Insulators are more sensitive than conductors and are dissipated by increasing temperatures and increasing voltage. The ground connection system is effective in keeping the insulation healthy. Connecting to the ground power supply is effective in improving the performance of the system. In all electrical installations, need a ground system, basically two types of grounding: protective grounding, electrical grounding, in some cases it is not possible to separate two types of ground connections for the above two purposes, and therefore creating a ground connection is sufficient for both purposes. Makes it more complicated. Protective earth: This type of protection system is used in creating safety for people who are in contact with electrical systems equipment and for people in the community who are the ultimate consumer of electricity. It is worth noting that the earth is not a partial protection of the electrical system. Electric earth: Electrical grounding means grounding the point of electrical devices that are part of the electrical circuit. Electrical grounding of the devices due to the proper operation of the devices and preventing the increase of electrical pressure of healthy phases relative to the earth during contact is one of the phases with the earth [4].

A. Earth's Network Standard

One of the most famous features for a ground system is its resistance. In terms of safety, the lower the resistance, the better the ground system is, but it should be noted that low ground resistance cannot be a measure of the safety of a network alone. In other words, there is no simple relationship between the size of the ground system resistance and the amount of possible shock to the person. A high-strength network may have better safety than a network with less resistance. In fact, other parameters such as network arrangement, short circuit current in it, location of ground bars, ground visa resistance, etc. They also affect the safety of the system. In any case, as a necessary and not sufficient condition, it can be said that the resistance of the earth system at one point should not exceed 10 ohms. Land resistance calculation: One of the methods for measuring soil specific strength is Wenner method and Schlumberger method [4,5].

Ground resistance calculation tests involve placing four electrodes at the same distances with the same burial depth and within a line in the ground. Two outer electrodes (called flow electrodes) inject the current into the soil. Two internal electrodes (called voltage electrodes) measure voltage, which is used to calculate soil specific strength. Soil resistance measurement with four-wire earth meter is performed by Wenner method in accordance with Figure 1 as follows [6,7]:

1- Four test mills are used. Two lateral affinity is considered for establishing the current circuit and two middle desires for voltage measurement. 2- All four mills are placed at equal distances in the same line. In each measurement, the location of all four desires must be changed. If the soil is homogeneous with the increase in the distance of the electrodes, the voltage changes linearly relative to the distance. 3- Test rods are placed on the ground at equal distances in one direction and connected to the terminals with four separate wire strands. 4- The depth of the pounding of the mills in the ground should not exceed one twentieth of their distance if the special equation is used. 5- Conductors related to current and voltage must be kept as far away from each other as possible in order to prevent cross-induction. 6- Because self-induction should be minimal, conductors should be completely opened from the pulleys. 7- The presence of extensive metal objects in the basement, such as metal piping of any kind and armor of cables, causes major disturbances in the measurement. Therefore, a path should be chosen in which such objects are not in the basement.

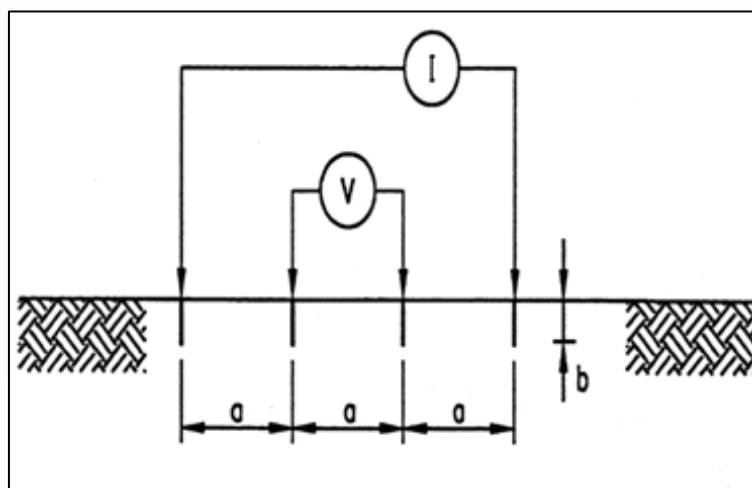

Fig. 1 Orbital structure of Wenner's experiment

Soil specific resistance measurement with four-wire earth meter is performed by Schlumberger method according to Figure 2 as follows [6,8]:

1- Four mills are installed in a straight line, but their distances are not equal to each other. The distance of current desires from each other is much greater than the distance of voltage currents from each other. 2- In this method, the voltage changes with the square of the distance between the current desires. Therefore, sensitive measuring instruments should be used when using it. 3- Conductors related to current and voltage should be kept as far away from each other as possible in order to prevent cross-induction. 4- Because self-induction should be minimal, conductors should be completely opened from the pulleys. 5- The presence of large metal objects underground, such as metal piping of any kind and armor of cables in measurement, causes major disturbances. 6- In measuring devices that use voltmeters or ohm meters, the resistance of the voltmeter or the voltage coil of the ohm meter must be large to reduce the resistance effect of the electrode or voltage electrodes.

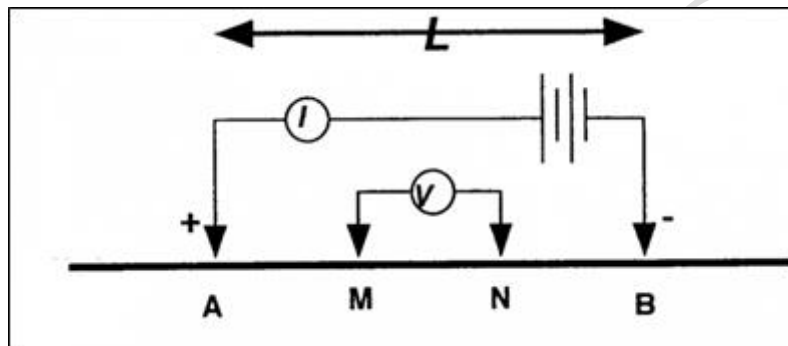

Fig. 2 Orbital structure of Schlumberger's experiment

B. Earth's Network Quality

A suitable ground system for performing its tasks must have the most important specifications: Low resistance, corrosion resistance, high flow through the ground, shelf life above 30 years in the meantime, low system resistance is very important and therefore, recognizing the effective factors in it can be helpful both for system design and maintenance and proper maintenance. One of the most important factors affecting the resistance of the earth system is soil specific resistance, which depends on these factors [4]:

1- Soil physical composition: Different soil compositions show different resistances and soil specific resistance with soil physical changes drastically changes. For example, for soft and clay soils, this resistance is about 2 ohms per meter and for rocky terrain is 1000 ohms per meter. 2- Moisture: Increasing soil moisture causes rapid reduction of soil specific resistance. This phenomenon has a great impact on areas where the difference in rainfall in summer and winter is high. An example of this effect is shown in the opposite form. That's why the earth rod should be planted deep enough to reach the wet soil. Electrical conductivity in soil is done as electrolytic conductivity and therefore soil resistance increases drastically by decreasing soil moisture. This is shown in a soil sample in the curve below. As can be seen, if the moisture content of this soil sample decreases more than 15%, its resistance increases with a steep slope. The amount of moisture in the soil depends on the compaction and size of the particles that make it up. 3- Chemical composition: Specific chemicals in soil such as salt have a great impact on reducing soil specific resistance. Of course, increasing salt, just as it reduces soil resistance, causes corrosion of underground equipment in the long term, thus reducing their life and increasing the resistance of the ground system. In fact, increasing salts in the soil, although in the short term, reduces the resistance of the earth system, but in the long run, it increases the resistance of the system again and also reduces its life. 4- Temperature: Ambient temperature has a significant impact on the resistance in such a way that with the cooling and freezing of the earth its special resistance increases. Therefore, the earth system may have good and low resistance in hot weather, but in cold weather its resistance is not desirable. Earth's resistance at -5°C can be 10 times higher than the resistance of the same earth at 20°C .

In addition to the above factors that affect the soil's specific resistance and therefore the earth's electrical resistance, the condition of the earth's electrodes is also effective in this case. This means that the use of several parallel electrodes with

minimum distance of 2 times the length of the electrode and the material of the electrode can be significantly effective in reducing the ground resistance.

C. Fragmentation of the Earth's Network

In fact, the fragmentation of the earth's network is caused by corrosion, which is defined by the corrosion of the buried network in the soil. In order for a structure to be corrosion in the soil, a corrosion cell must be formed, now accepting this, we will explain the conditions in which a corrosion cell can be carried out: a) There should be a cathode and an anode. b) There should be a potential difference between the anode and the cathode. c) The anode and cathode must be located in a conductive environment. There are conditions for an electrode of ground connection buried in the soil (non-homosexual metals change the oxygen concentration of soil material, etc.) which leads to the formation of anode and cathodic points and conditions A and B are supplied, and condition C is provided by considering that the moisture in the soil is considered as an electrolyte. The fragmentation of the earth's network causes problems in the protection and electrical tasks of this network, which should necessarily be detected, then we simulate and investigate this problem and compare the normal state of the earth network with the fragmented state of the earth network in the specialized CDEGS software.

II. ANALAYSS & CONCLUSION

For proper and structural comparison of the earth network, in addition to healthy mode and full grid according to Figure 3, we consider and model two separated states of 3 pieces and 2 pieces according to figures 4 and 5.

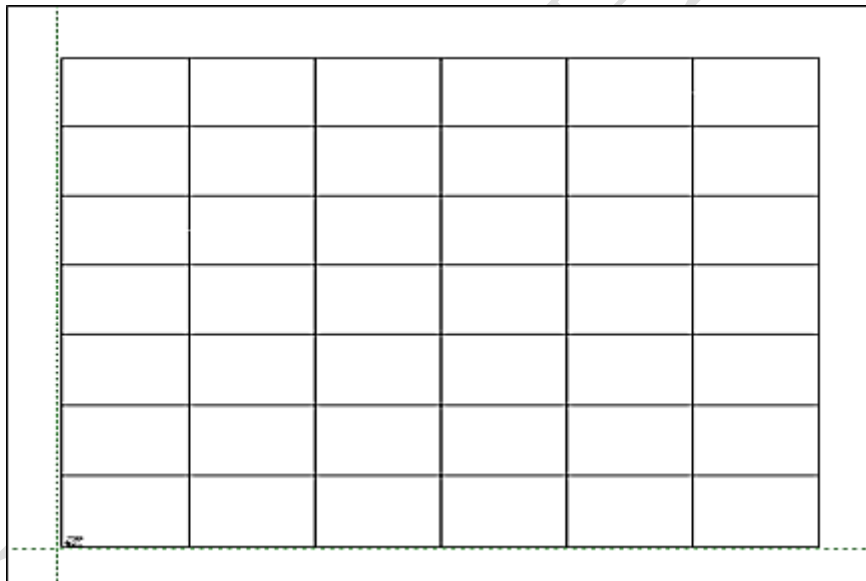

Fig. 3 Modeling and implementation of 1-piece network

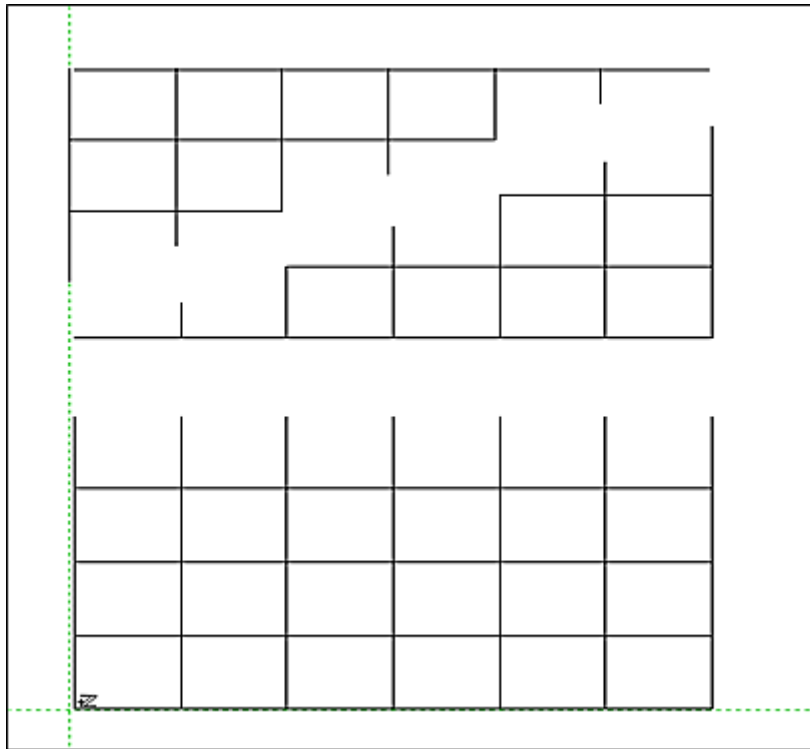

Fig. 4 Modeling and implementation of 2-piece network

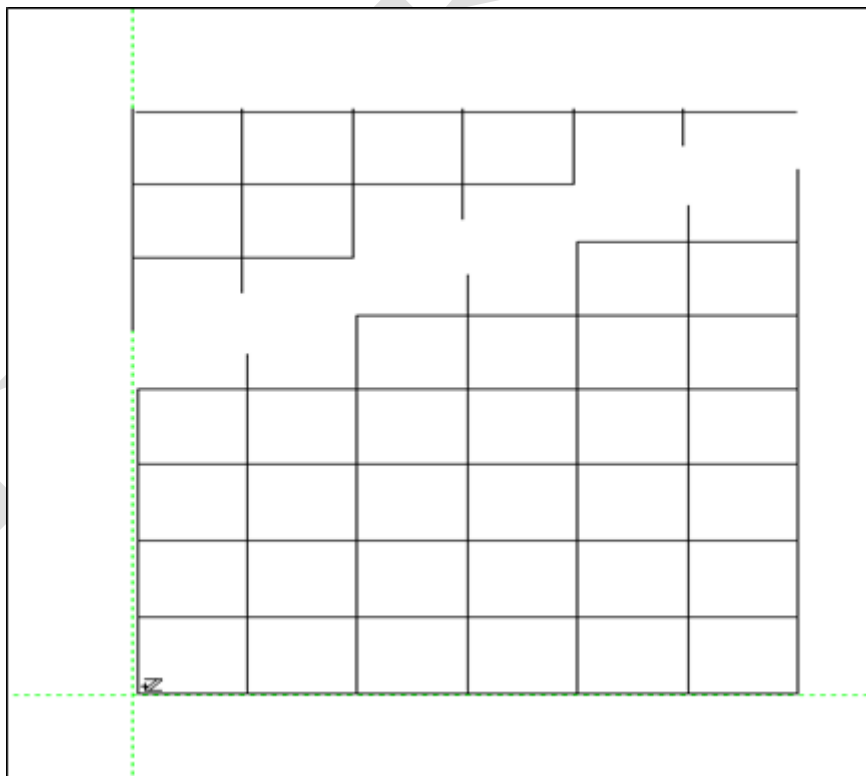

Fig. 5 Modeling and implementation of 3-piece network

A. Earth's Network Resistance

First, the ground structure is implemented, defined and calculated the ground resistance in the specialized technical software CDEGS.

In fact, ground resistance can be obtained through two standard IEEE methods, Wenner and Schlumberger, by entering the numbers obtained from the megger device. of course, in CDEGS software, using a simple method, ground resistance can be obtained and imported by defining a variety of soil models according to figures 6 to 9.

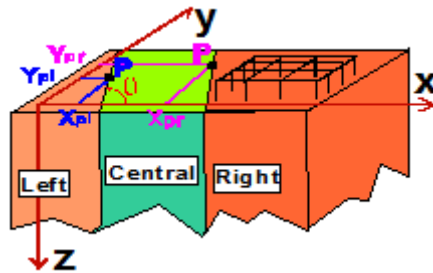

Fig. 6 Defining a variety of soil models

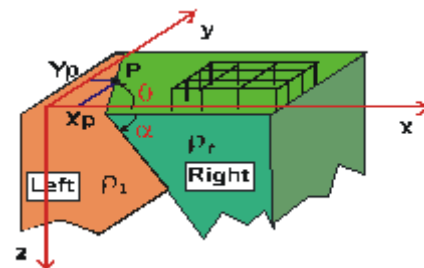

Fig.7 Defining a variety of soil models

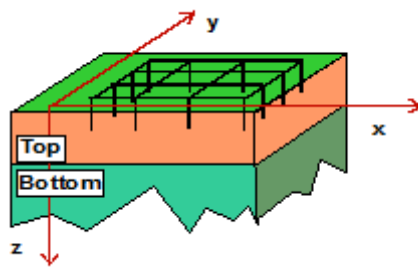

Fig. 8 Defining a variety of soil models

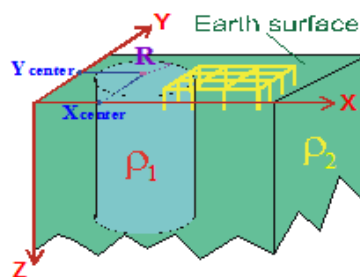

Fig.9 Defining a variety of soil models

Finally, implement the general specifications of the earth network in the specialized CDEGS software.

B. Step and Touch voltages

Step and touch voltages are specified in accordance with IEEE standard [9,10,11] and are located and defined according to the resistance of gloves or shoes as well as the time of error fixing in the safety and security section of the software.

In earth networks, when lightning strikes, the earth system plays a big role in transmitting the transient waves created to the earth. Since lightning frequency can vary from 100 kilos to 1 MHz, this makes investigating the earth system at different high frequencies very important.

In high voltage substations, the probability of lightning is high, also in high voltages substations due to soil properties and problems in ground system implementation and environmental conditions, the earth network is exposed to fragmentation, so studying the earth's network at high frequencies is very important.

In fact, through CDEGS software, study the contact voltages and step in high frequencies in fragmented networks and investigate voltage profiles.

III. Simulation Results and Calculations of Step and Touch Voltage Profiles

In order to research on the fragmented challenge of the earth and to accurately understand the problems of occurrence of this problem, 3 networks "1 piece - 2 pieces - 3 pieces" in 3 frequencies " 50 Hz - 100 kHz - 1 " implement and simulate step and contact voltages for buried network at a depth of 0.75 cm of soil with a resistance of 150 ohms per meter at the time of occurrence of an error current as large as 31,500 amps. To get it.

1-1: 1-piece network at 50 Hz: First, implement the 1-piece earth network and at a frequency of 50 Hz obtain step and touch voltages according to figures 10 and 11, and also in figures 12 and 13, we display regional current and shunt current in this mode.

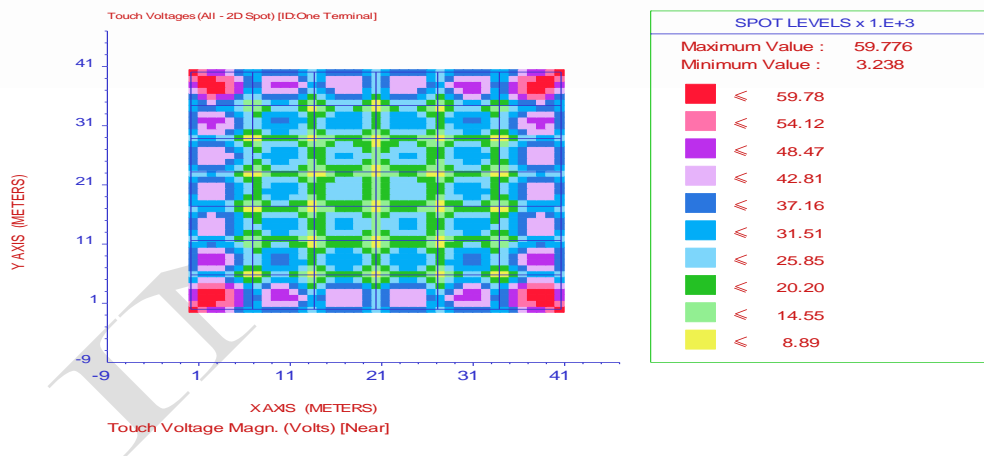

Fig. 10 1-piece earth network and at frequency of 50 Hz, obtained touch voltage

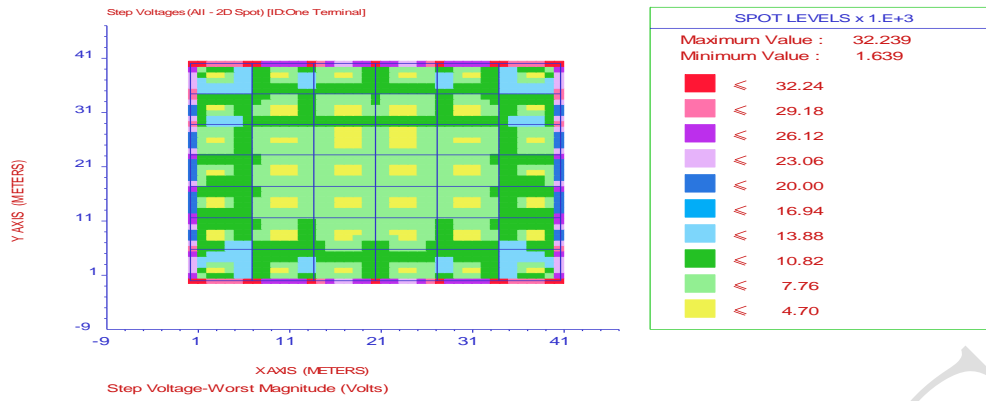

Fig. 11 1-piece earth network and at frequency of 50 Hz, obtained step voltage

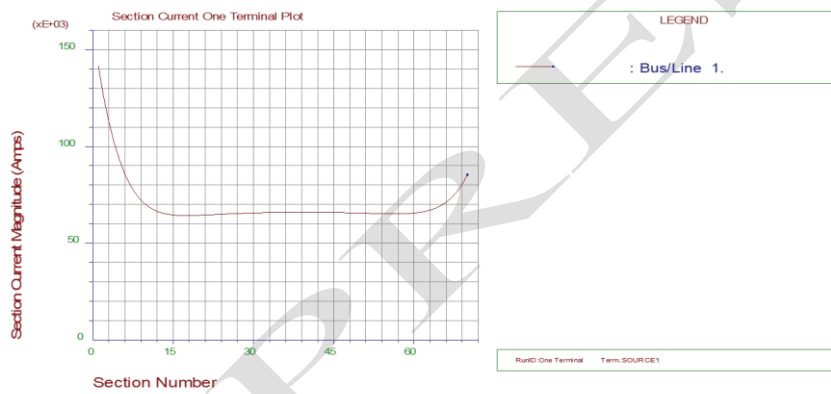

Fig. 12 1-piece earth network and at a frequency of 50 Hz obtain regional current

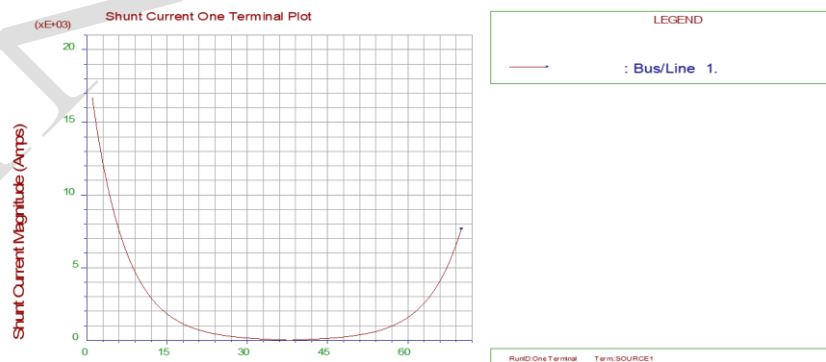

Fig. 13 1-piece earth network and at a frequency of 50 Hz obtain shunt current

Finally, the voltage profiles of the earth's grid are drawn in 1 piece and at a frequency of 50 Hz according to Figure 14.

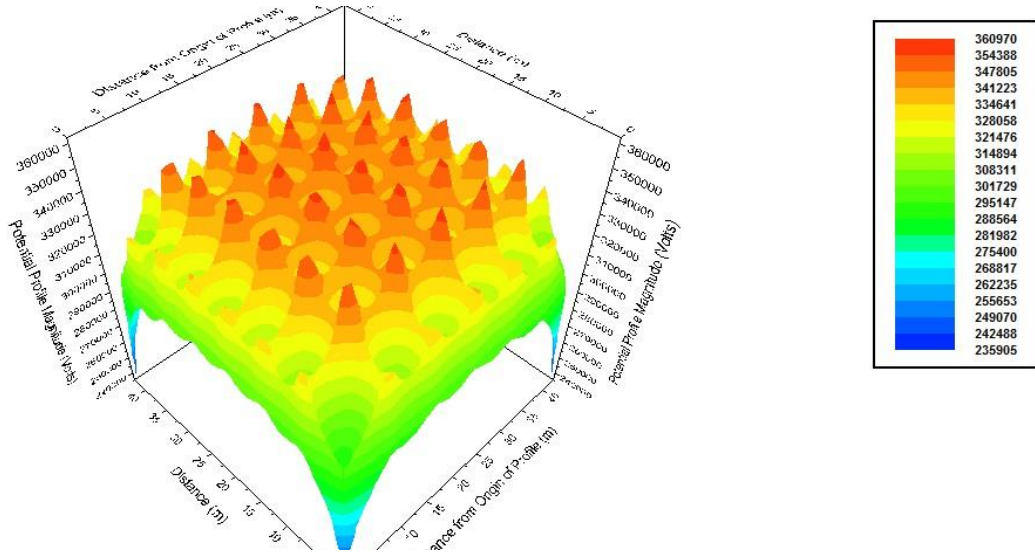

Fig. 14 The voltage profiles of the earth's grid in 1 piece and at frequency of 50 Hz

1-2: 1-piece network at 100 kHz: First implement the 1-piece ground network and at a frequency of 100 kHz, obtain step and touch voltages in accordance with figures 15 and 16, and also in figures 17 and 18, display regional flow and shunt current in this mode.

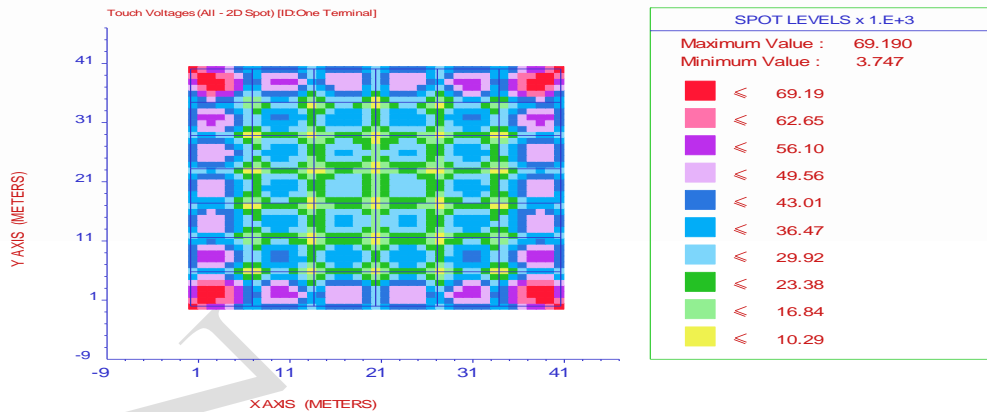

Fig. 15 1-piece earth network and at frequency of 100 kHz, obtained touch voltage

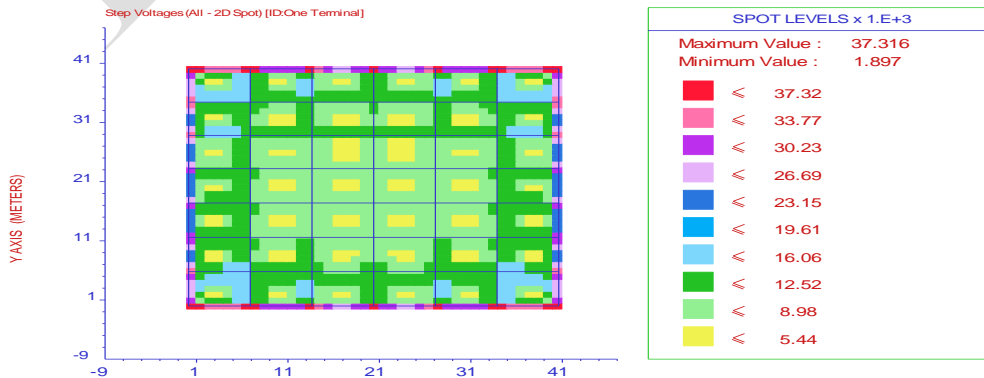

Fig. 16 1-piece earth network and at frequency of 100 kHz obtained step voltage

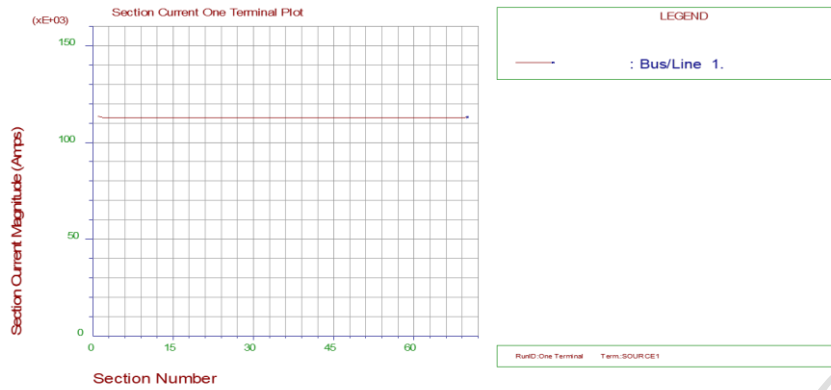

Fig. 17 1-piece earth network at frequency of 100 kHz, obtained regional current

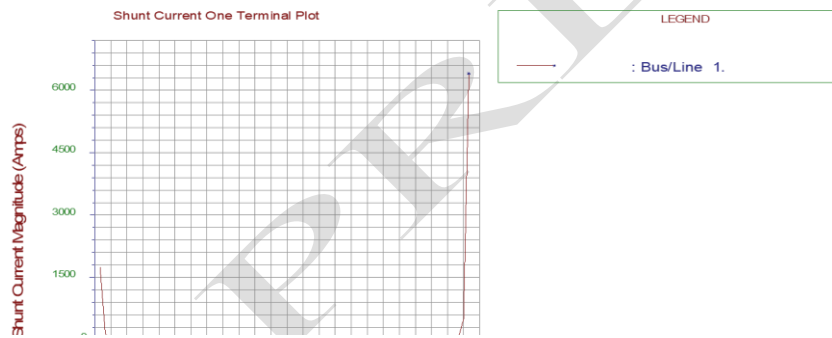

Fig. 18 1-piece earth network and at frequency of 100 kHz, obtained shunt current

Finally, the voltage profiles of the earth's grid are drawn in 1 piece and at a frequency of 100 kHz according to Figure 19.

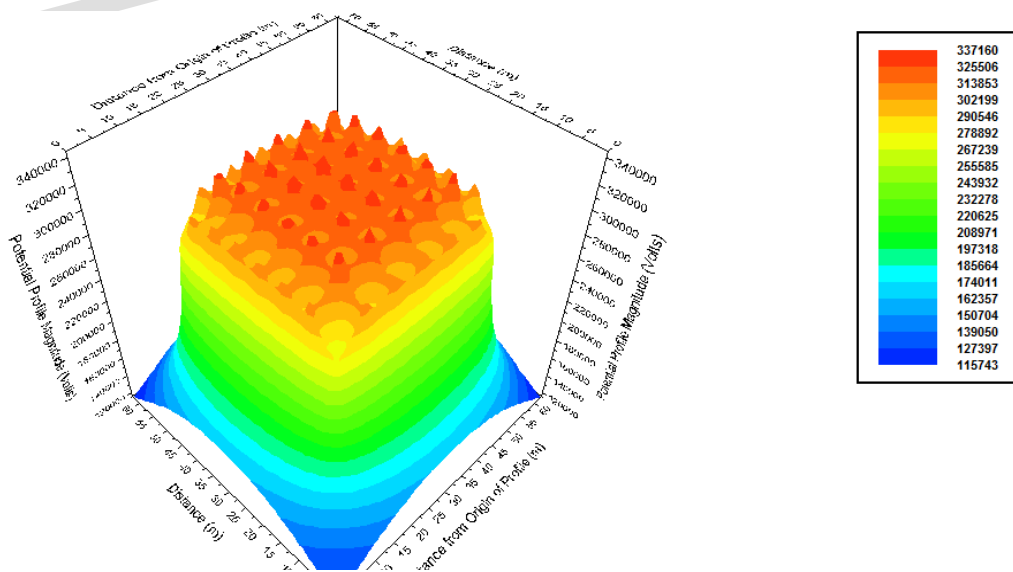

Fig. 19 The voltage profiles of the earth's grid in 1 piece and at frequency of 100 kHz

3-1: 1-piece network at 1 MHz: First, we implement the 1-piece earth network and at a frequency of 1 MHz, we obtain step and touch voltages in accordance with figures 20 and 21, as well as in figures 22 and 23, we display regional currents and shunt currents in this mode.

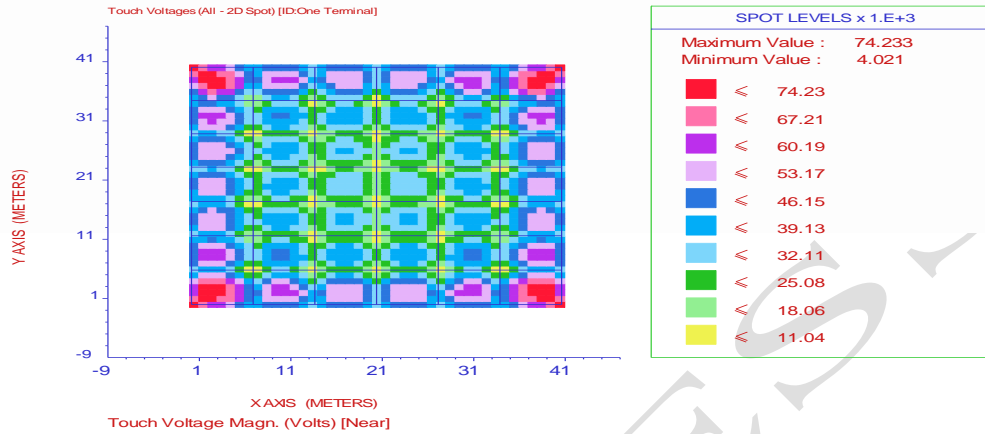

Fig. 20 1-piece earth network and at frequency of 1 MHz, obtained touch voltage

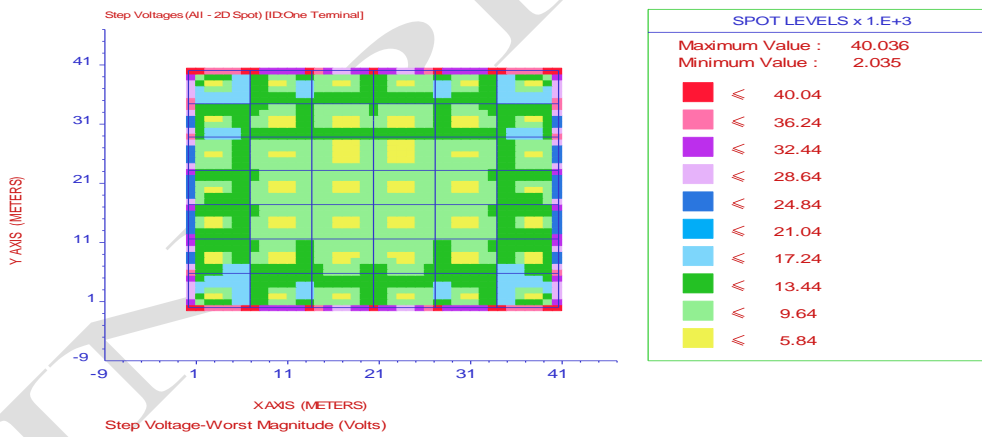

Fig. 21 1-piece earth network and at frequency of 1 MHz obtained step voltage

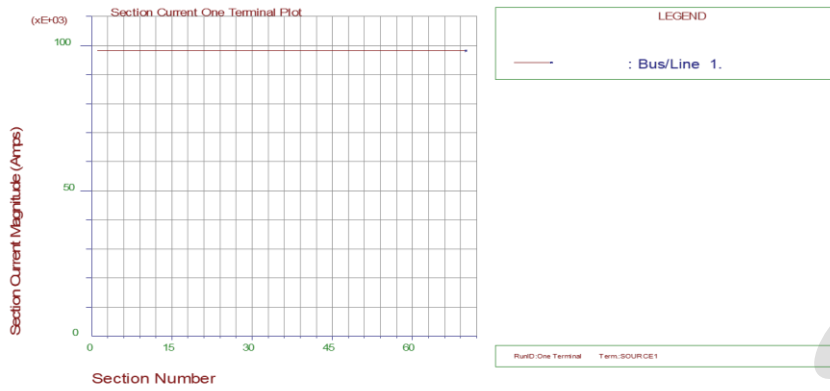

Fig. 22 1-piece earth network and at frequency of 1 MHz, obtained regional current

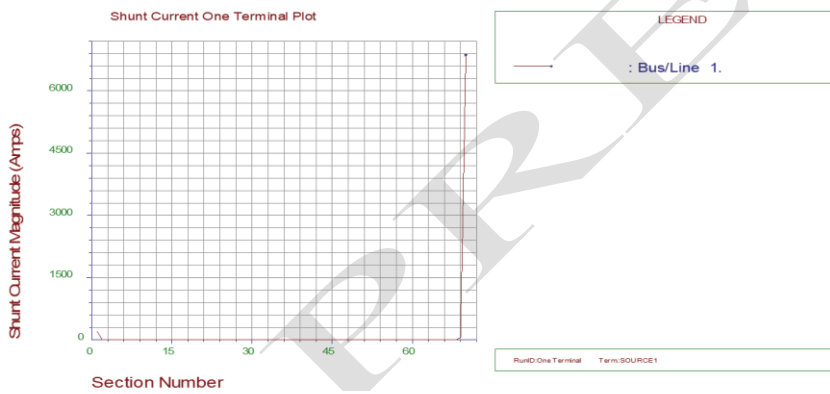

Fig. 23 1-piece earth network and at a frequency of 1 MHz obtain shunt current

Finally, the voltage profiles of the earth's grid are drawn in 1 piece mode at a frequency of 1 MHz in accordance with Figure 24.

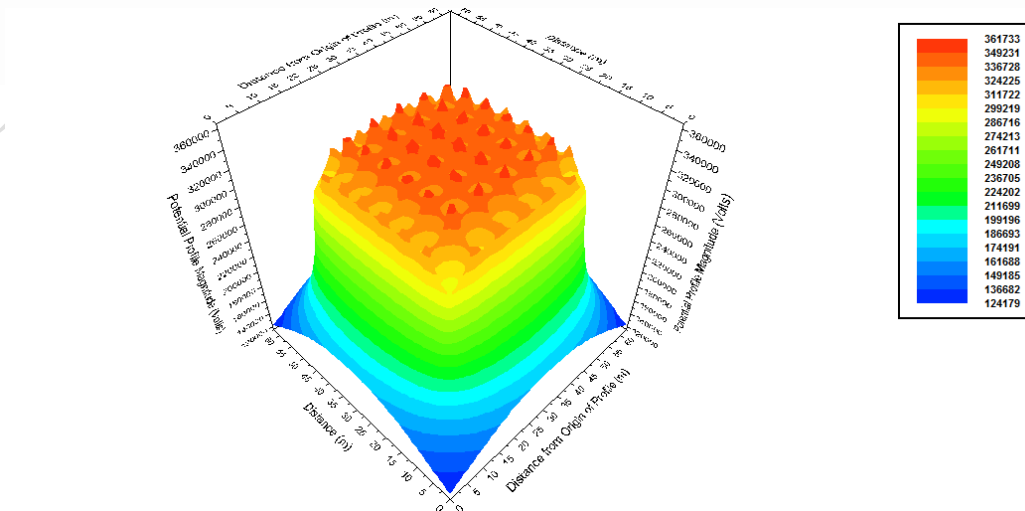

Fig. 24 The voltage profiles of the earth's grid in 1 piece and at frequency of 1 MHz

By comparing the voltage profiles based on the simulation results of the 1-piece fixed network at different frequencies of 50 Hz, 100 kHz and one MHz, it was determined that by increasing the critical voltage frequency, especially near the earth's network, the critical voltage should be increased.

1-2: 2-piece network at 50 Hz: First, we implement the 2-piece ground network and at 50 Hz frequency we obtain step and touch voltages in accordance with figures 25 and 26, as well as in figures 27 and 28, we display regional currents and shunt currents in this mode.

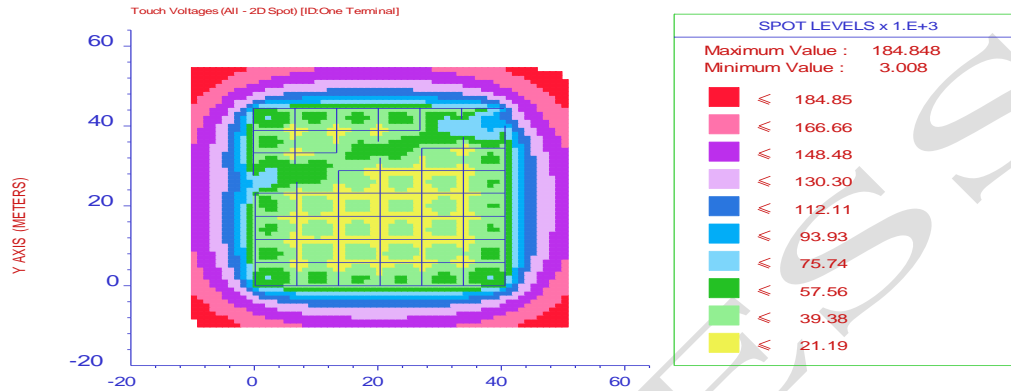

Fig. 25 2-piece earth network and at frequency of 50 Hz, obtained touch voltage

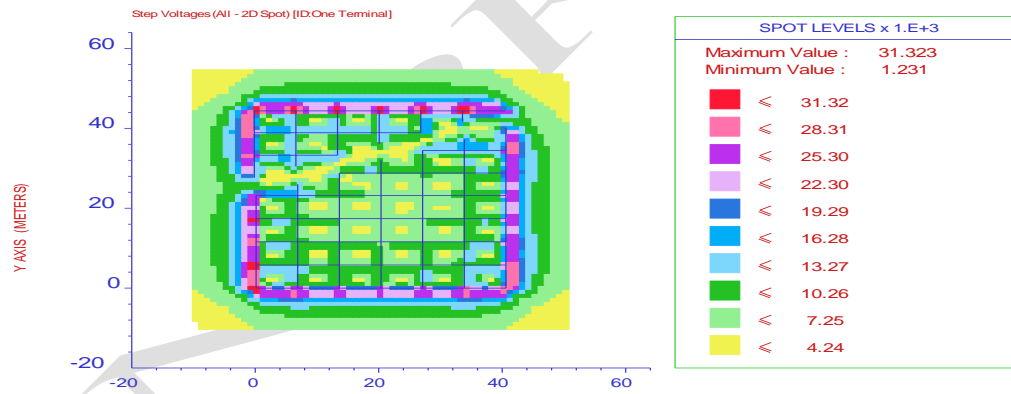

Fig. 26 2-piece earth network and at frequency of 50 Hz, obtain touch voltage

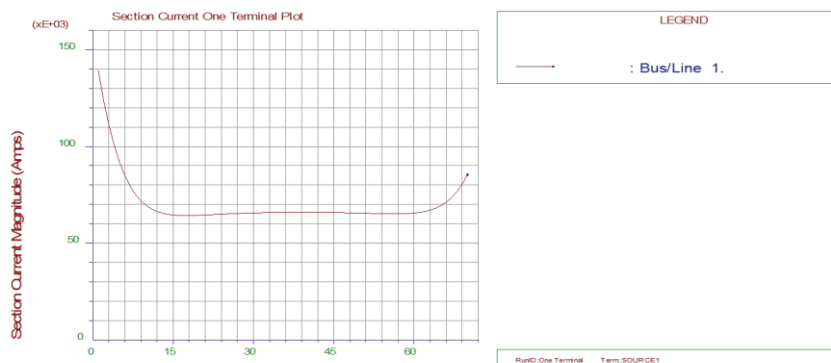

Fig. 27 2-piece earth network and at frequency of 50 Hz, obtain regional current

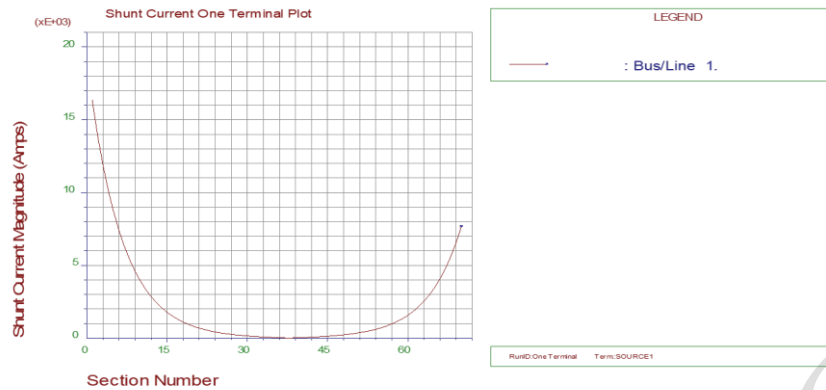

Fig. 28 2-piece earth network and at a frequency of 50 Hz obtain shunt current

Finally, the voltage profiles of the earth's grid are drawn in 2 pieces and at a frequency of 50 Hz according to Figure 29.

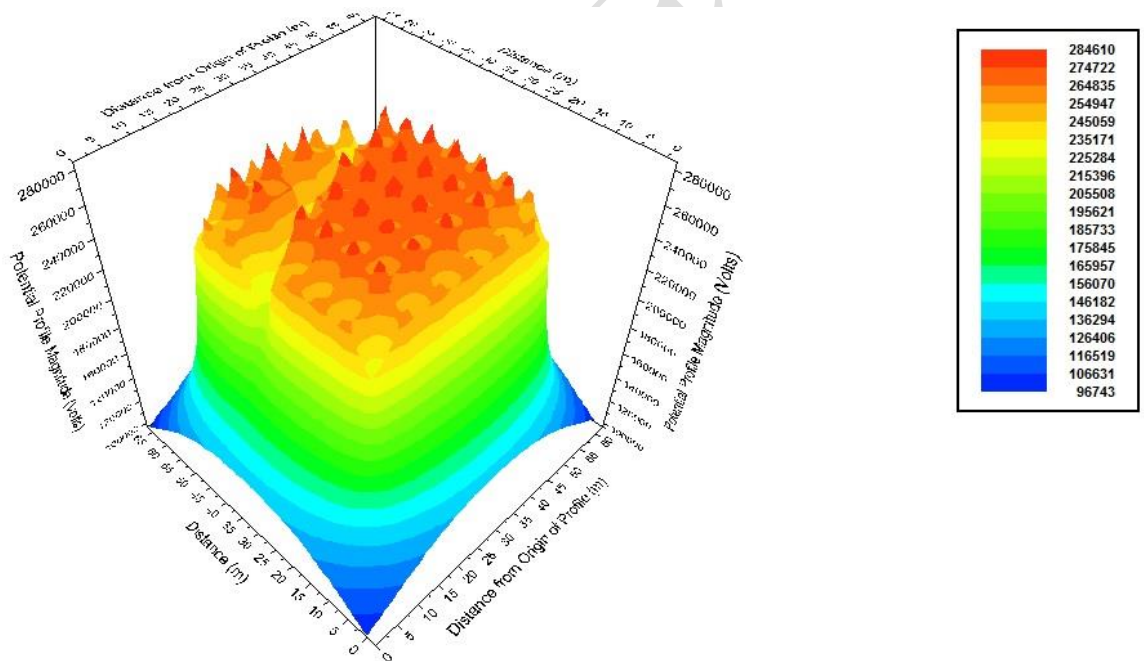

Fig. 29 The voltage profiles of the earth's grid in 2 piece and at a frequency of 50 Hz

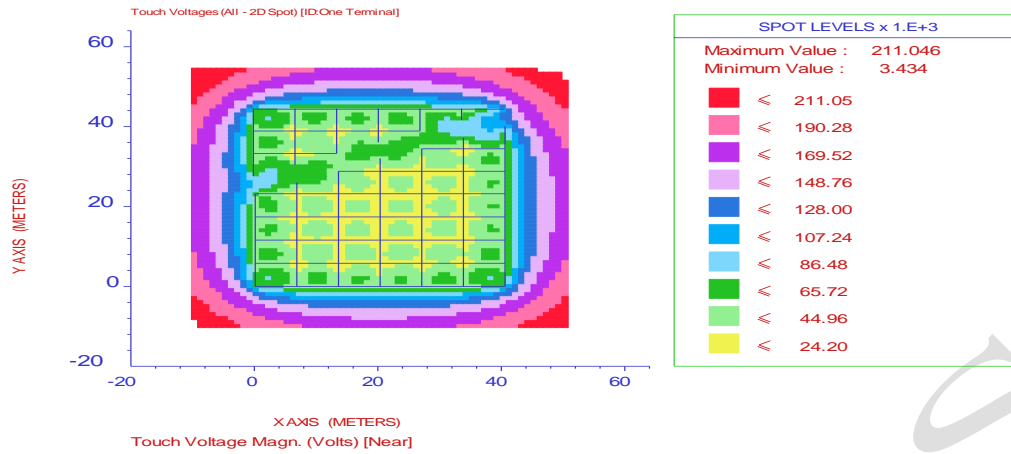

Fig. 30 2-piece earth network and at frequency of 100 kHz, obtained touch voltage

2-2: 2-piece network at 100 kHz: First, implement the 2-piece ground network and at a frequency of 100 kHz, obtain step and touch voltages in accordance with figures 30 and 31, as well as in figures 32 and 33, display regional flow and shunt current in this mode.

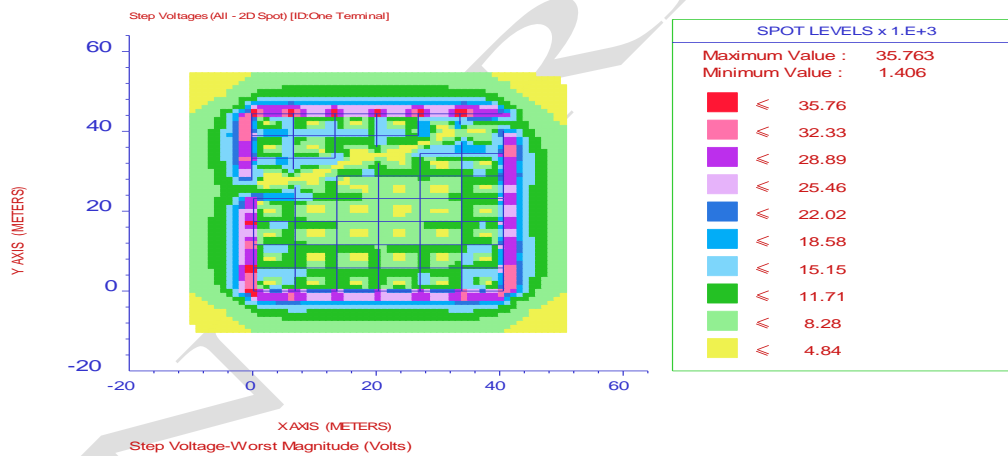

Fig. 31 2-piece earth network and at frequency of 100 kHz, obtained step voltage

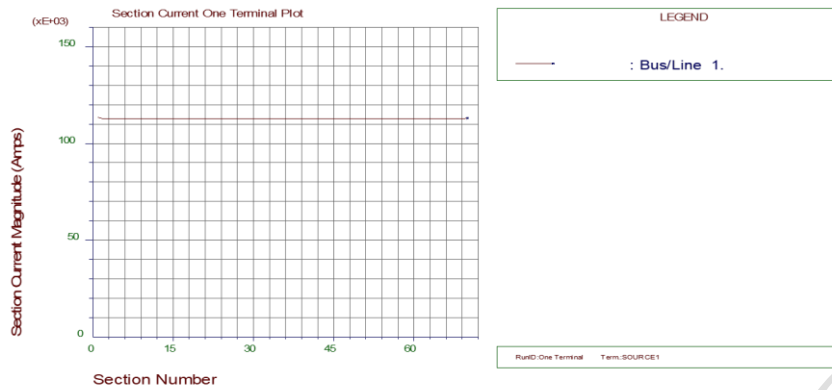

Fig. 32 2-piece earth network and at frequency of 100 kHz obtained regional current

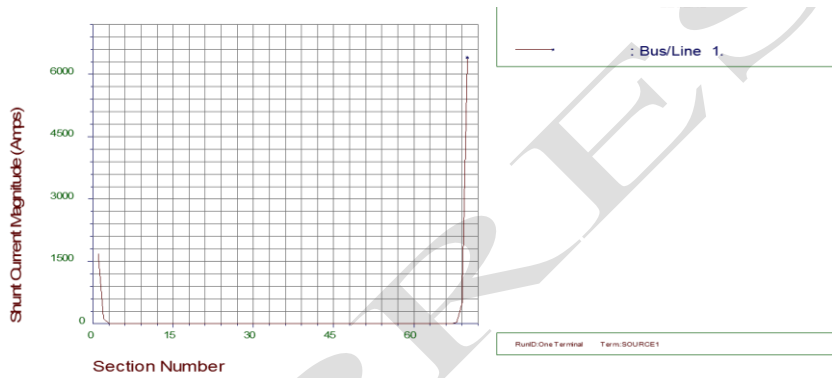

Fig. 33 2-piece earth network and at frequency of 100 kHz, obtained shunt current

Finally, the voltage profiles of the earth's grid are drawn in 2 pieces and at a frequency of 100 kHz according to Figure 34.

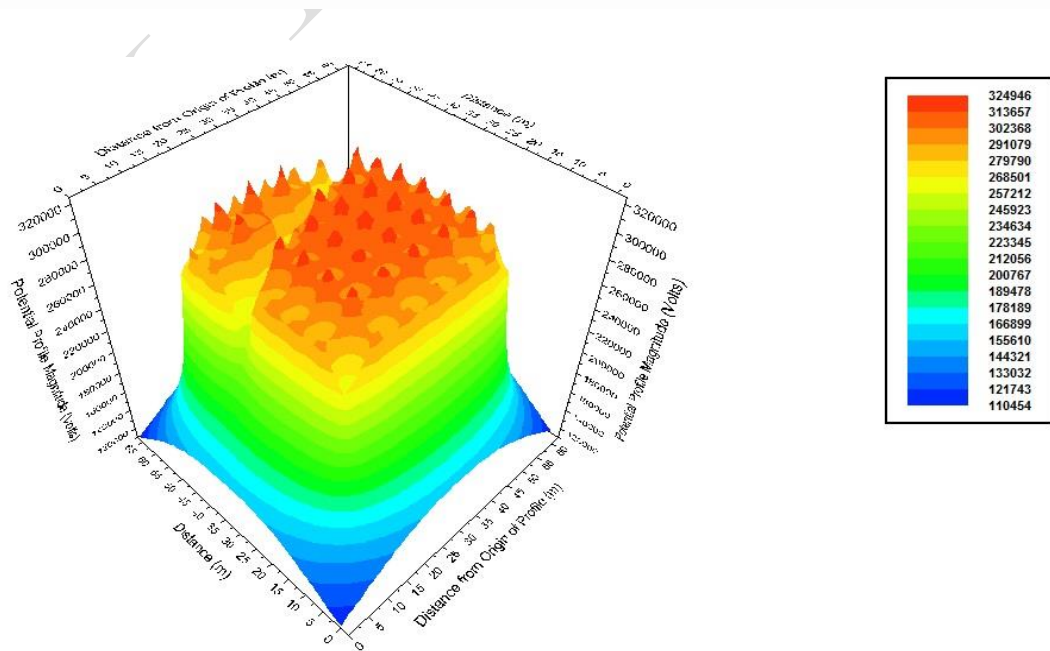

Fig. 34 The voltage profiles of the earth's grid in 2 piece and at frequency of 100 kHz

3-2: 2-piece network at 1 MHz: First, implement the 2-piece earth network and at a frequency of 1 MHz obtain step and touch voltages according to figures 35 and 36, as well as in figures 37 and 38, display regional currents and shunt currents in this mode.

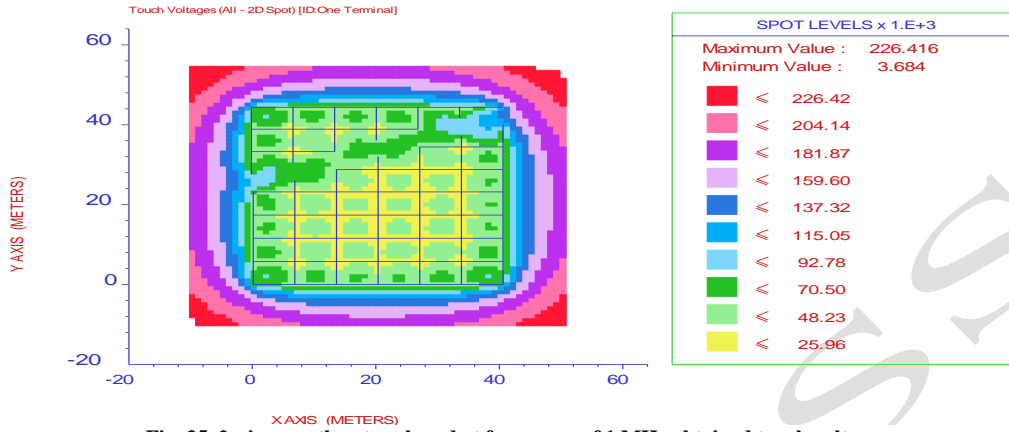

Fig. 35 2-piece earth network and at frequency of 1 MHz obtained touch voltage

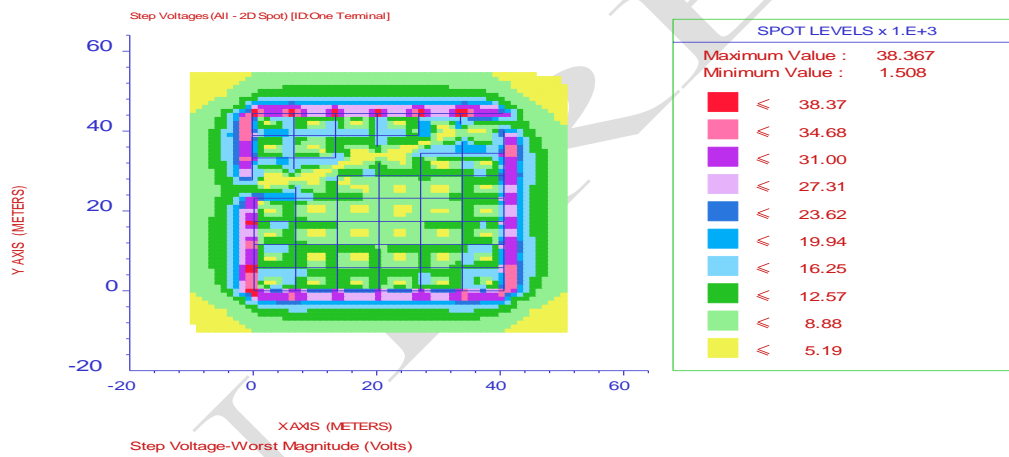

Fig. 36 2-piece earth network and at frequency of 1 MHz obtained step voltage

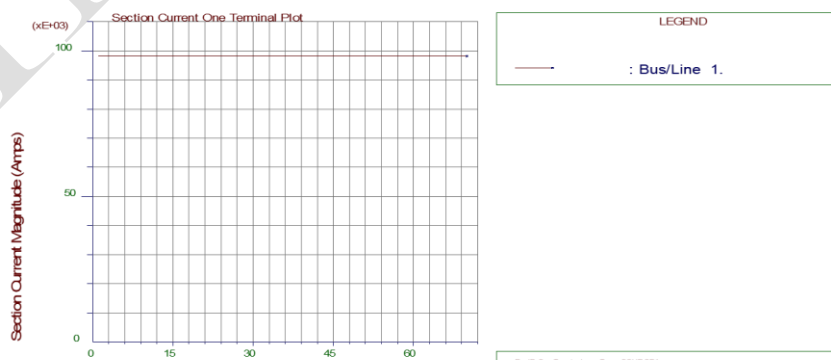

Fig. 37 2-piece earth network and at frequency of 1 MHz, obtained regional current

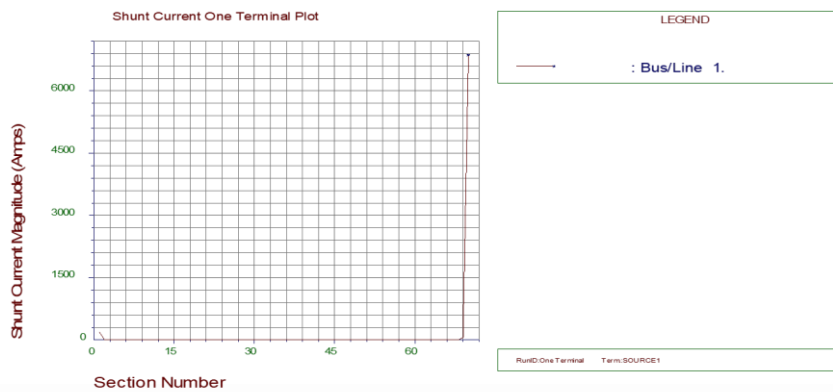

Fig. 38 2-piece earth network and at frequency of 1 MHz, obtained shunt current

Finally, the voltage profiles of the earth's grid are drawn in 2-piece mode at a frequency of 1 MHz in accordance with Figure 39.

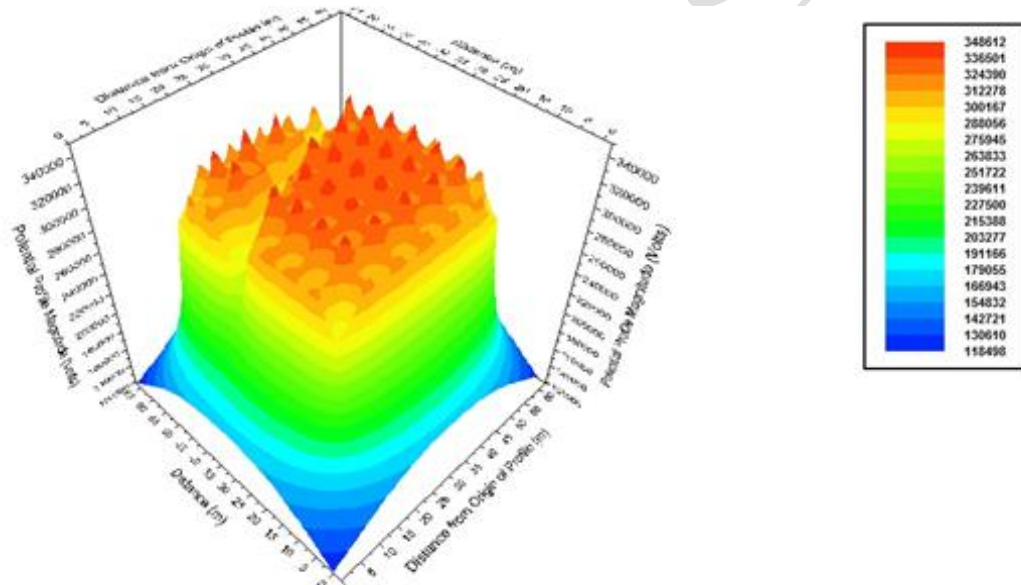
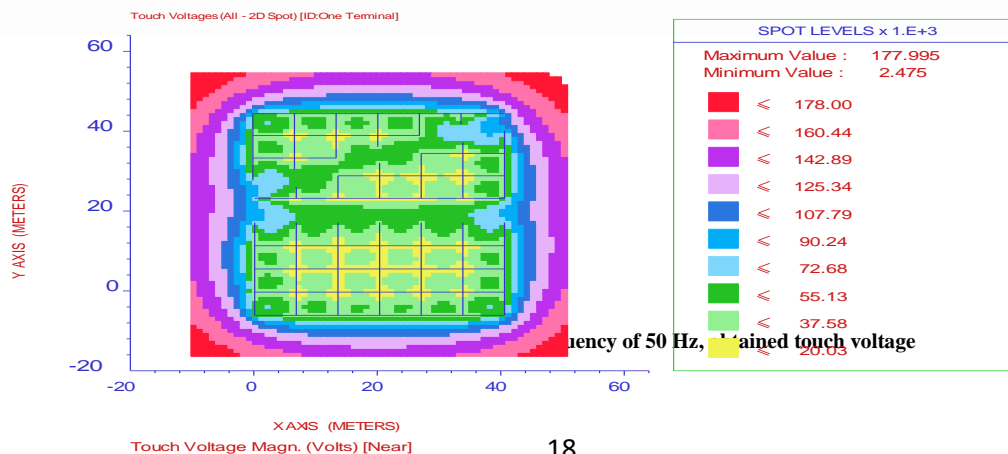

Fig. 39 The voltage profiles of the earth's grid in 2 piece and at a frequency of 1 MHz

1-3: 3-piece network at 50 Hz: First, implement the 3-piece ground network and at a frequency of 50 Hz, obtain step and touch voltages according to figures 40 and 41, and also in figures 42 and 43, display regional currents and shunt currents in this mode.



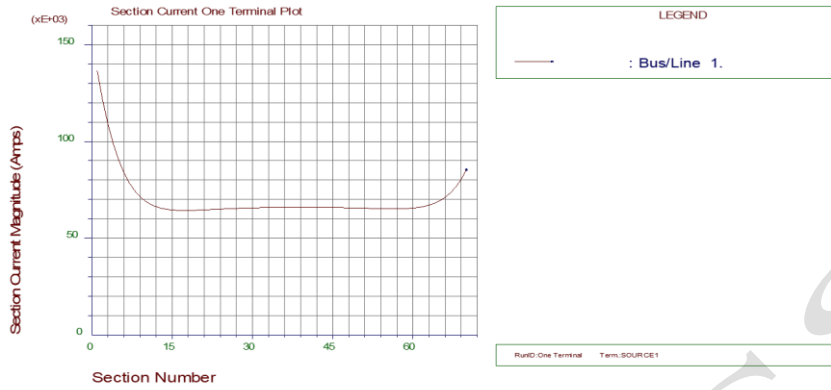

Fig. 41 3-piece earth network and at frequency of 50 Hz obtained touch voltage

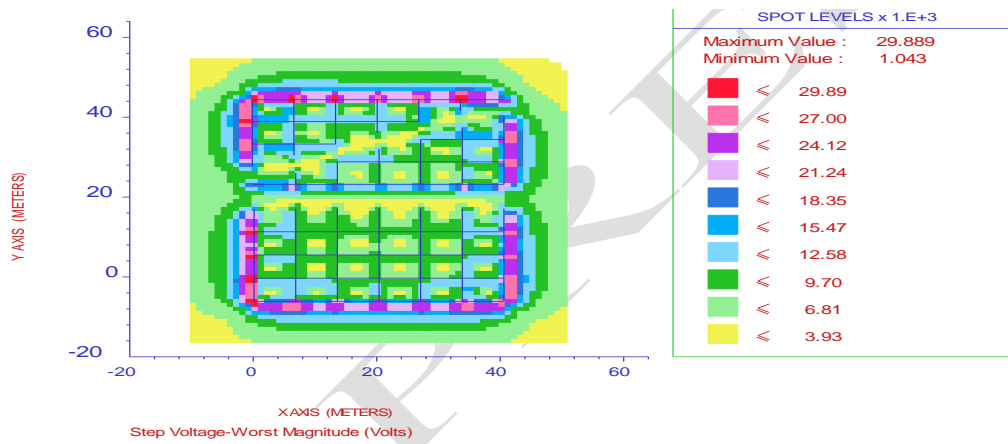

Fig. 42 3-piece earth network and at frequency of 50 Hz obtained regional current

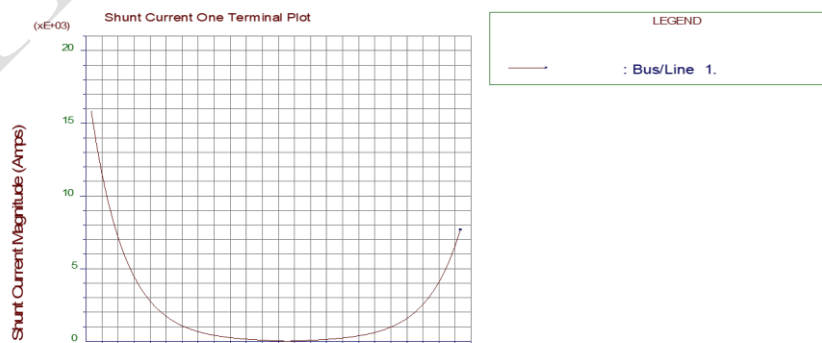

Fig. 43 3-piece earth network and at frequency of 50 Hz, obtained shunt current

Finally, the voltage profiles of the earth's grid are drawn in 3 pieces and at a frequency of 50 Hz according to Figure 44.

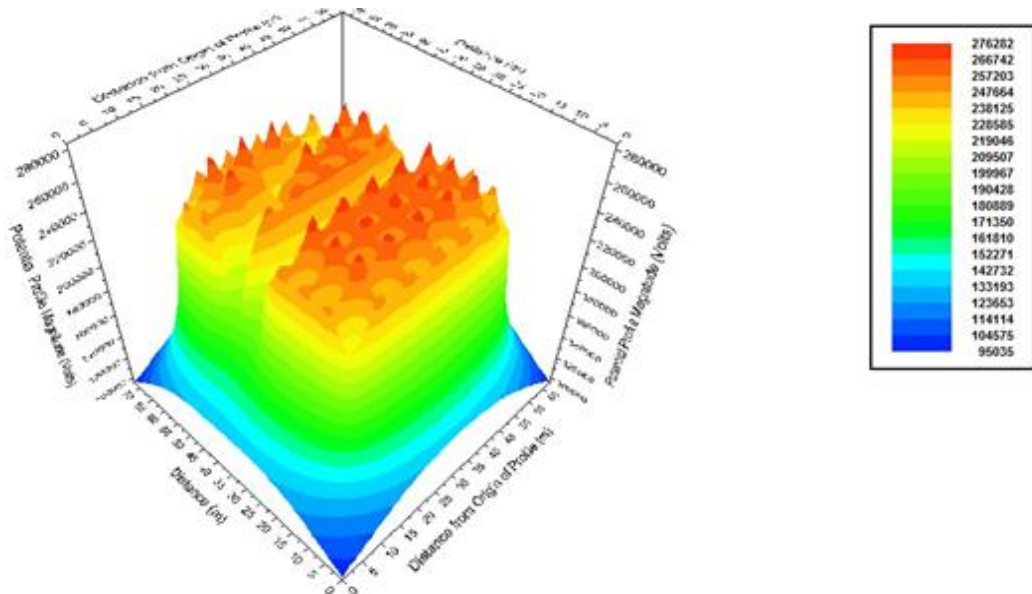

Fig. 44 The voltage profiles of the earth's grid in 3 piece and at frequency of 50 Hz

2-3: 3-piece network at 100 kHz: First, implement the 3-piece ground network and at a frequency of 100 kHz, obtain step and touch voltages in accordance with figures 45 and 46, and also show regional current and shunt current in 47 and 48 forms.

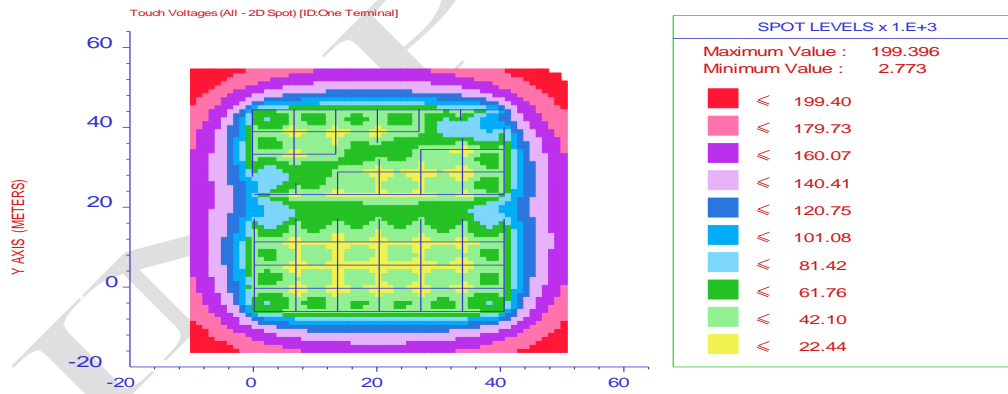

Fig. 45 3-piece earth network and at frequency of 100 kHz, obtained touch voltage

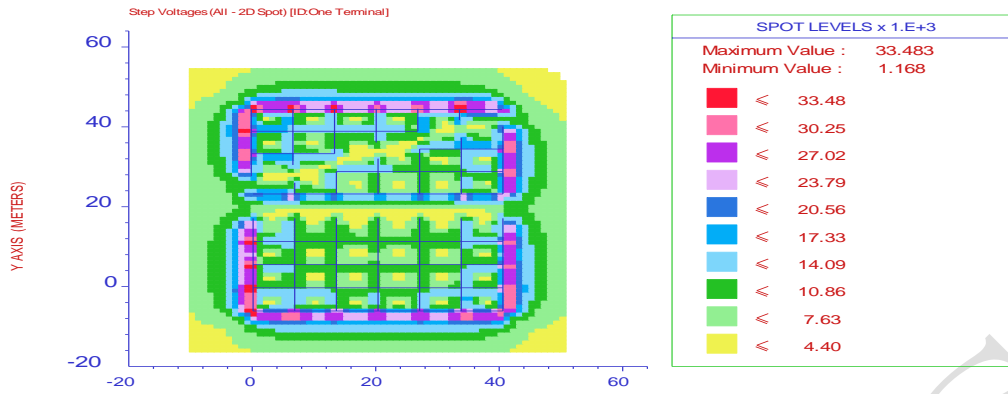

Fig. 46 3-piece earth network and at a frequency of 100 kHz obtain step voltage

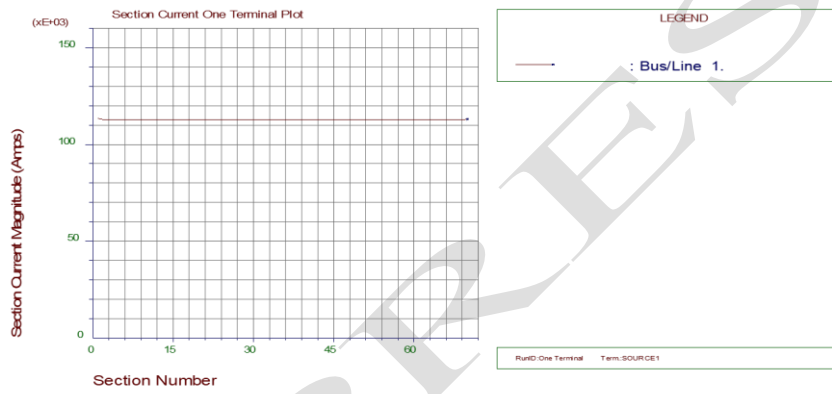

Fig. 47 3-piece earth network and at a frequency of 100 kHz obtain regional current

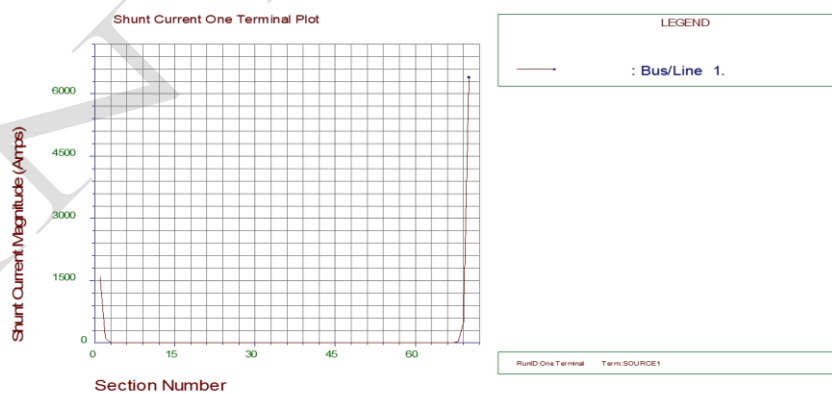

Fig. 48 3-piece earth network and at frequency of 100 kHz, obtained regional current

Finally, the voltage profiles of the earth's grid are drawn in 3 pieces and at a frequency of 100 kHz according to Figure 49.

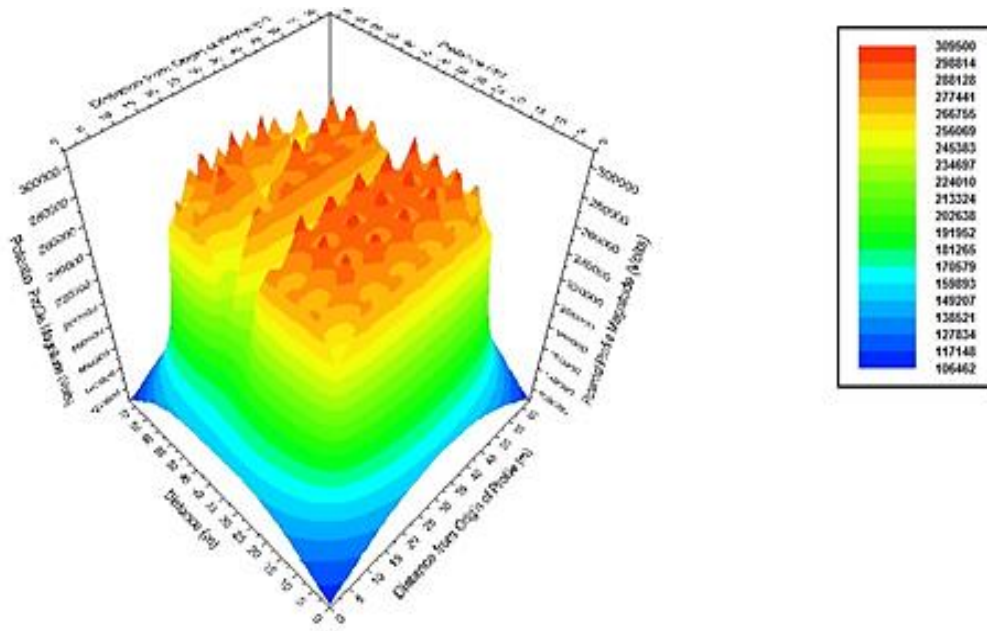

Fig. 49 the voltage profiles of the earth's grid in 3 piece and at frequency of 100 kHz

3-3: 3-piece network at 1 MHz: First, implement the 3-piece earth network and at a frequency of 1 MHz obtain step and touch voltages according to figures 50 and 51, as well as in figures 52 and 53, display regional current and shunt current in this mode.

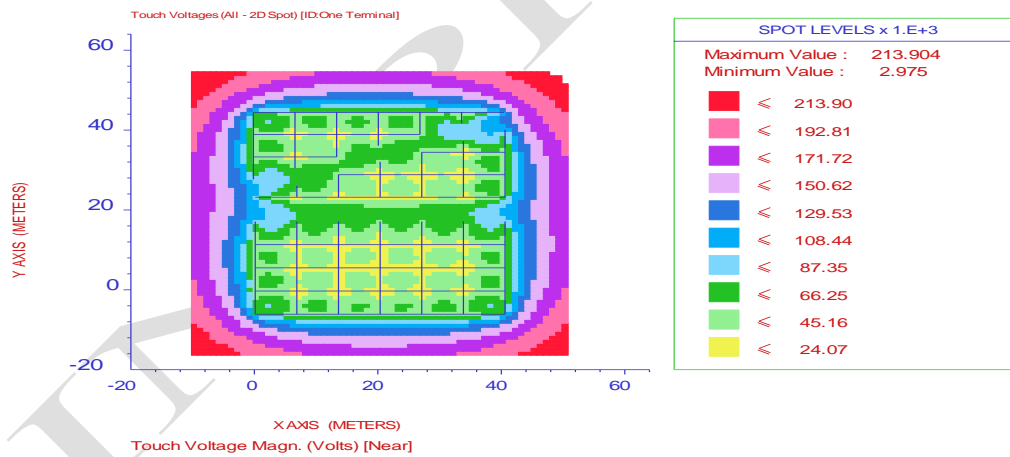

Fig. 50 3-piece earth network and at frequency of 1 MHz, obtained touch voltage

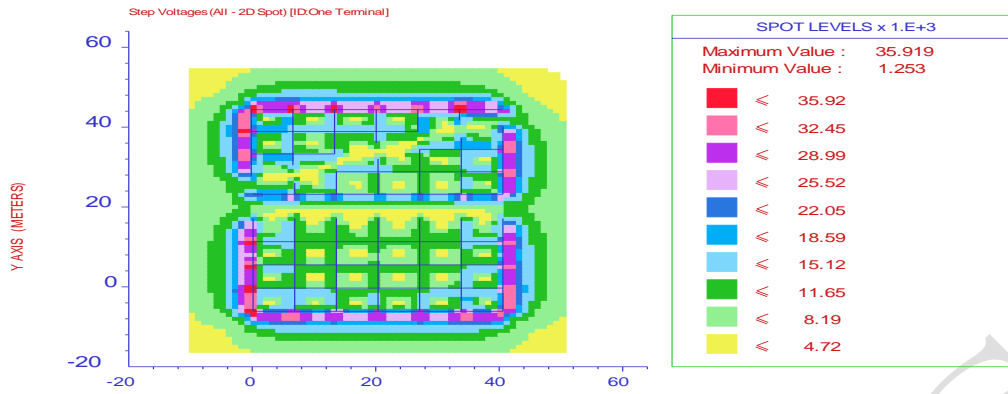

Fig. 51 3-piece earth network and at frequency of 1 MHz obtained step voltage

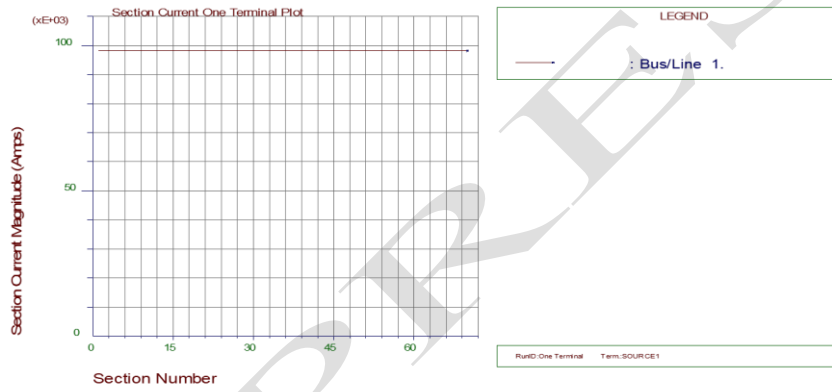

Fig. 52 3-piece earth network and at frequency of 1 MHz, obtained regional current

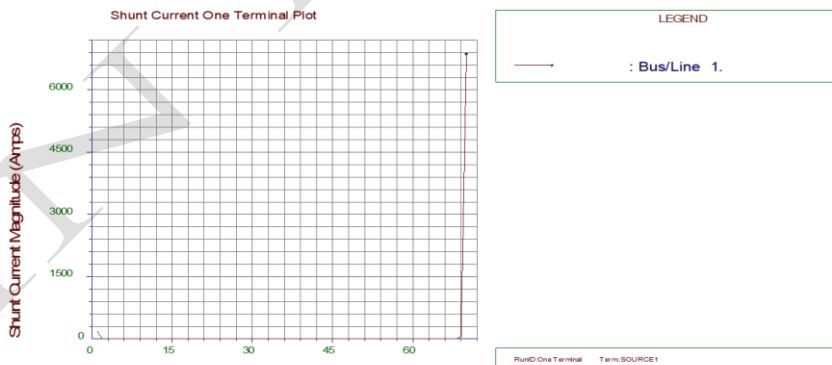

Fig. 53 3-piece earth network and at frequency of 1 MHz, obtained regional current

Finally, the voltage profiles of the earth's grid are drawn in 3-piece mode at a frequency of 1 MHz in accordance with Figure 54.

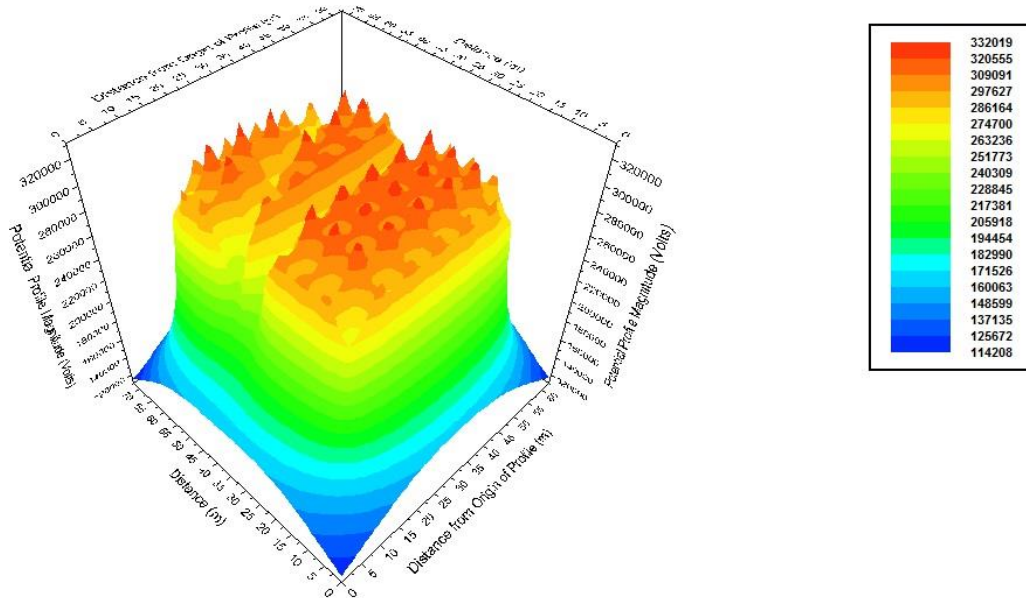

Fig. 54 the voltage profiles of the earth's grid in 3 piece and at frequency of 1 MHz

IV. CONCLUSIONES

By comparing the voltage profiles based on the simulation results, it was found that by increasing the frequency of the contact voltage in each profile and mesh, it is noticeably increased. Analysis and diagrams indicated that in each case one or more pieces of the Earth's network increases with increasing the frequency of the step voltage value in each loop. The point to consider after reviewing the simulation results is that by increasing the frequency of both step voltage and touch voltage in the corner points, they are more increased than other parts. Also, the research in this paper clearly proved that the fragmentation of the Earth's network along with increasing frequency causes critical points in the ground network detachments in the center of each network, which causes the problem of inefficiency and fundamental failure of the earth's network and completely weakens and overshadows the performance and tasks of the earth's network, in fact, this fragmentation causes a sharp increase in step and touch voltages. And the call is made at the points where the network has been destroyed, and the increase in frequency also exacerbates the incident.

V. CRediT AUTHORSHIP CONTRIBUTION STATEMENT

Asaad Shemshadi: Conceptualization, Methodology, Software, Validation, Formal Analysis, Research, Resources, Data Curation, Writing - Original Draft, Writing - Proofreading and Editing, Visualization, Supervision, Project Management, Fund Acquisition, **Pourya Khorampour:** Conceptualization, Methodology, Software, Validation, Formal Analysis, Research, Resources, Data Curation, Writing - Original Draft, Writing - Proofreading and Editing, Visualization, Supervision, Project Management, Fund Acquisition.

Books:

- [1] Zedan B. Characterisation of substation earth grid under high frequency and transient conditions. Cardiff University (United Kingdom); 2005.
- [2] Korvin G. Fractal models in the earth sciences. Amsterdam: elsevier; 1992 Jan.
- [7] Wenner F. A method of measuring earth resistivity. US Government Printing Office; 1916.

Journals:

- [3] SHARAFI D, KLAPPER U. High Voltage Substation Earth Grid Impedance Testing. Technical article on earthgrid impedance testing using CPC100 and CP CU1, WESTERN POWER–Australia, OMICRON electronics.
- [4] Meliopoulos AP, Moharam MG. Transient analysis of grounding systems. IEEE Transactions on Power Apparatus and Systems. 1983 Feb(2):389-99.
- [5] Colella P, Pons E, Tommasini R. The identification of global earthing systems: A review and comparison of methodologies. In 2016 IEEE 16th International Conference on Environment and Electrical Engineering (EEEIC) 2016 Jun 7 (pp. 1-6). IEEE.
- [6] Plowman RJ. Lightning and EMC: a review and Introduction.

- [8] Zohdy AA. A new method for the automatic interpretation of Schlumberger and Wenner sounding curves. *Geophysics*. 1989 Feb;54(2):245-53.
- [9] Prasad D, Sharma HC. Significance of step and touch voltages. *International Journal of Soft Computing and Engineering (IJSCE)*. 2011 Nov 5;1(5):193-7.
- [10] Wang W, Velazquez R, Mukhedkar D, Gervais Y. A practical probabilistic method to evaluate tolerable step and touch voltages. *IEEE transactions on power apparatus and systems*. 1984 Dec(12):3521-30.
- [11] Kosztaluk R, Gervais Y. Field measurements of touch and step voltages. *IEEE transactions on power apparatus and systems*. 1984 Nov(11):3286-94.

Asaad Shemshadi was born on 1 November 1979. He received the B.Sc. degree from Shiraz University, in 2003, the M.Sc. degree from Kashan University, in 2007, and Ph.D. from Khaje Nasir Toosi University of Technology in 2014, Tehran, Iran, all in electrical engineering. Since 2016, he has worked as an assistant professor and a member of the academic staff of Arak University of Technology. His main research interests are vacuum interrupters design and analysis, high voltage simulations, DGA techniques, plasma modeling, high voltage equipment optimized design and transients in the vacuum arc quenching process. <https://orcid.org/0000-0002-7271-9933>

Pourya Khorampour was born on 14 September 1996. He received the B.Sc. degree from Arak University of Technology as 1st rank, in 2018. He is the M.Sc. student at Arak University of Technology, in 2019, all in electrical engineering. Since 2018, His main research interests are power systems dynamics, power systems protection, and high voltage simulations. <https://orcid.org/0000-0002-8718-6519>